

RIGHT-FRONT VIEW

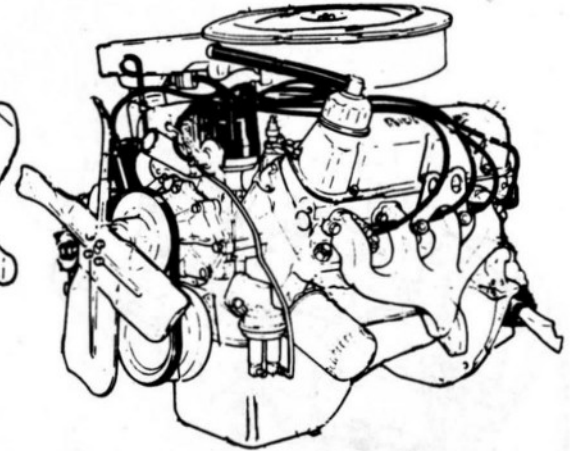

LEFT FRONT VIEW

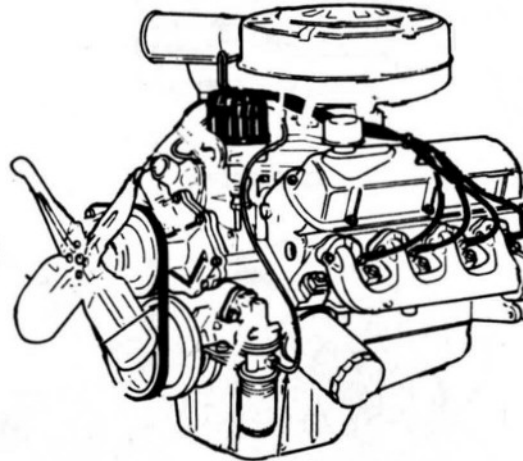
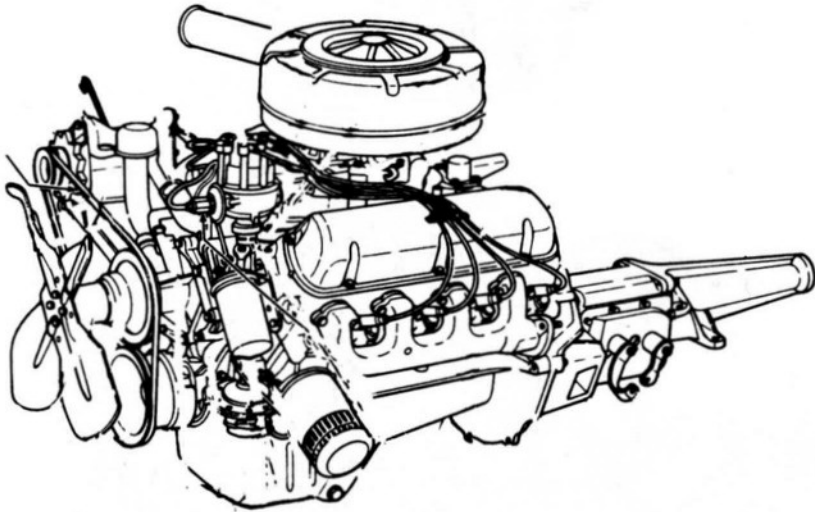

LEFT-FRONT VIEW

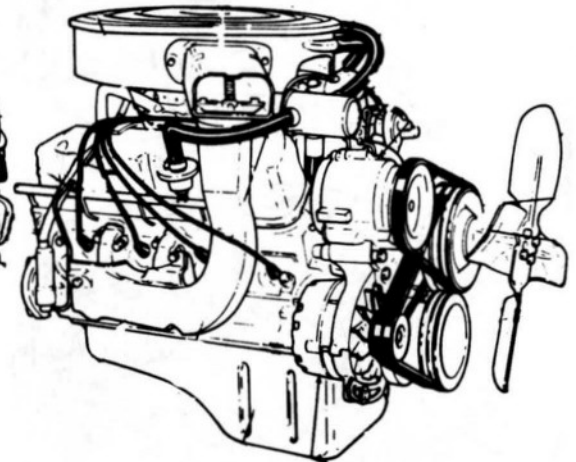

8-221, 260, 289 TYPICAL
Picture 1963-64

8-289 TYPICAL
Picture 1965-68

8-302, 351, 400 TYPICAL
Picture 1968-72

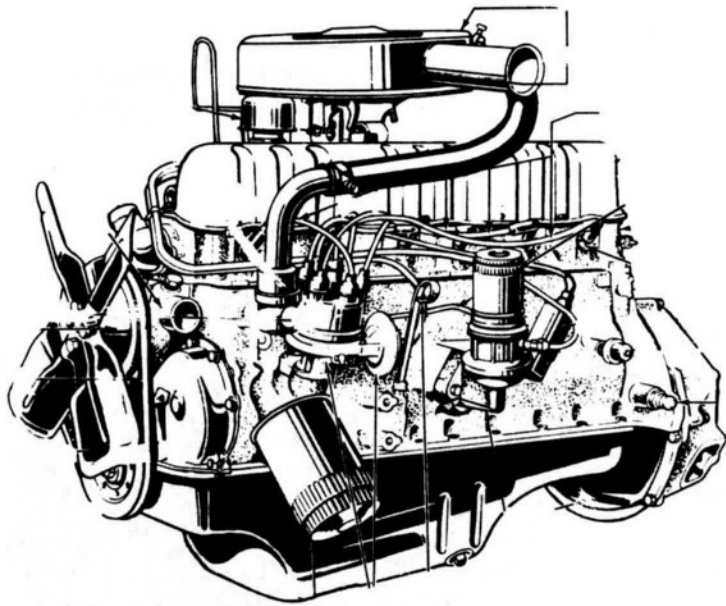

6-144, 170 TYPICAL

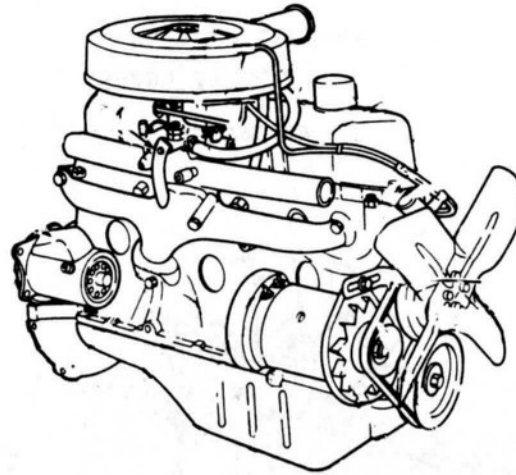

RIGHT-FRONT VIEW

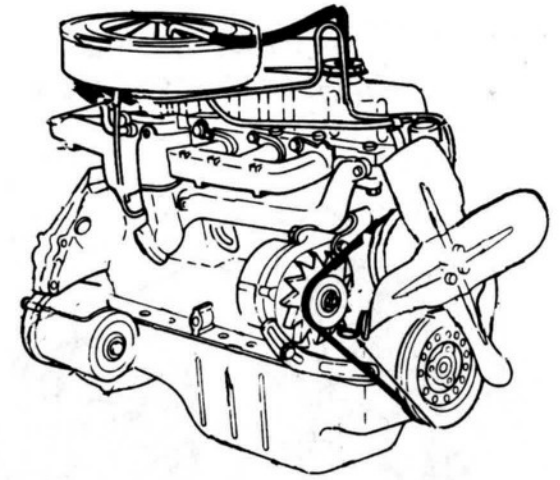

RIGHT-FRONT VIEW

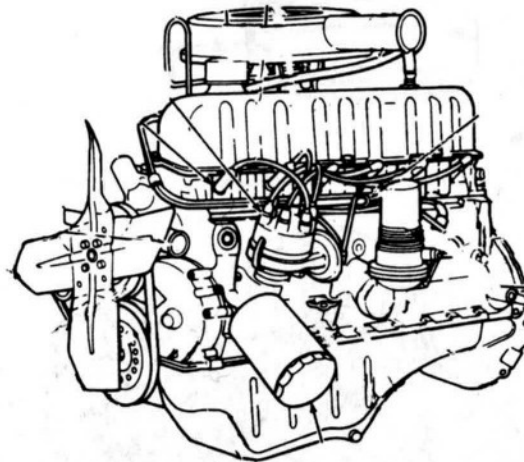
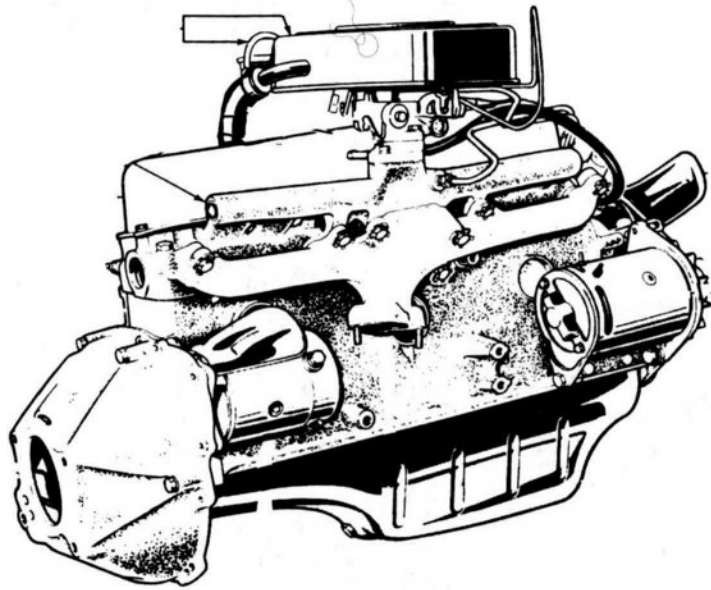

LEFT-FRONT VIEW

6-170, 200, 250 TYPICAL
Picture 1965-72

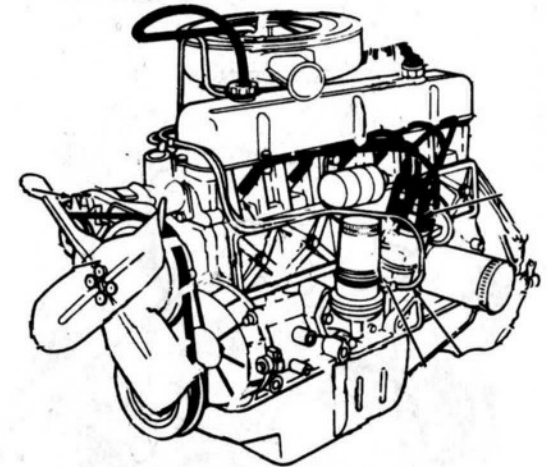

LEFT-FRONT VIEW

6-240 TYPICAL
Picture 1965-69

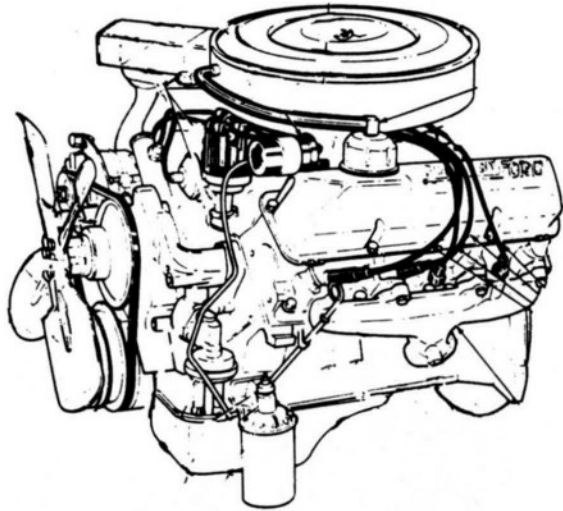

LEFT FRONT VIEW

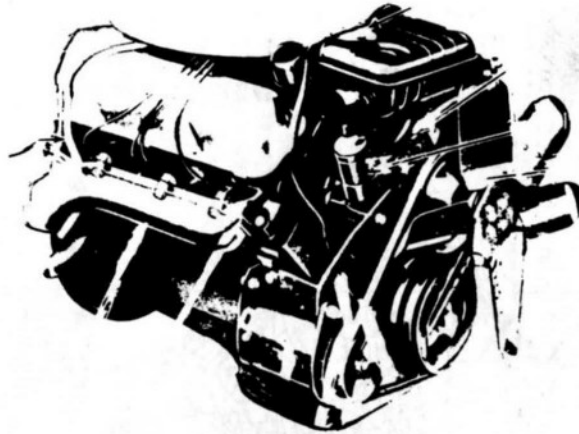

8-390 TYPICAL
Picture 1963-64

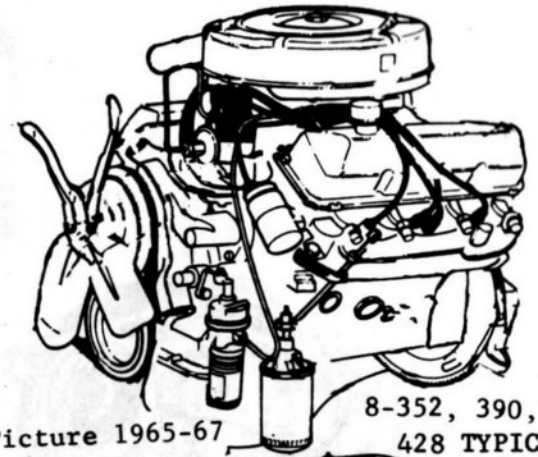

Picture 1965-67, 8-352, 390,
428 TYPICAL

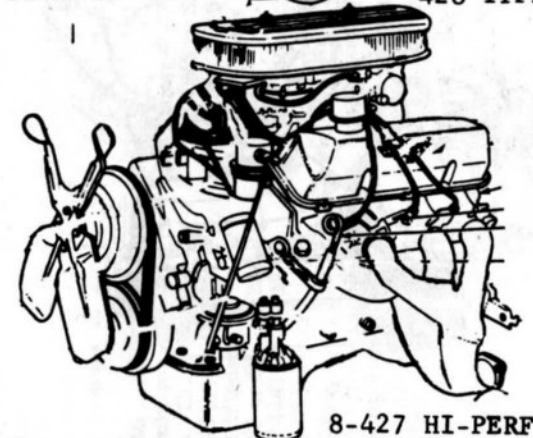

Picture 1965-69 8-427 HI-PERF

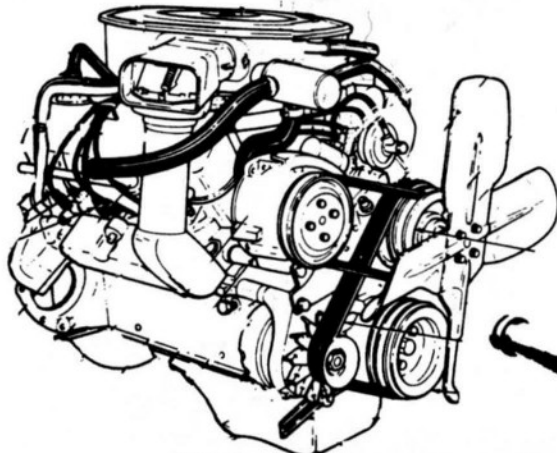

RIGHT FRONT VIEW

8-390, 428 TYPICAL
Picture 1969-70

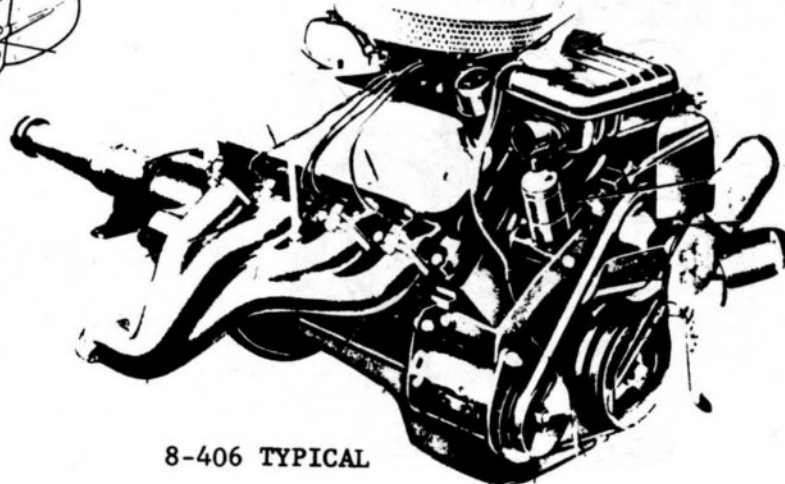

8-406 TYPICAL

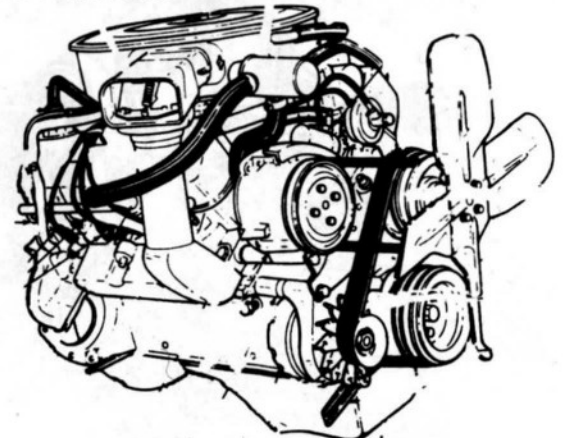

8-390, 428 TYPICAL
Picture 1968-71

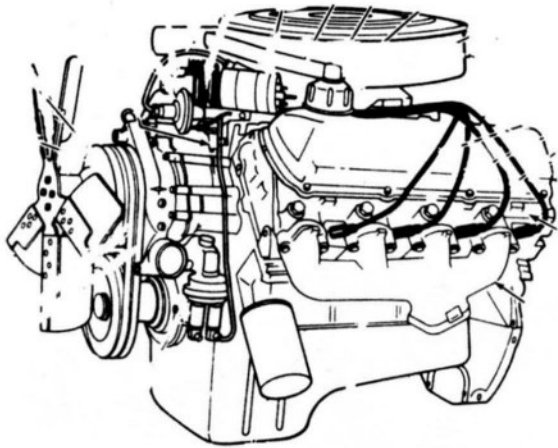

LEFT-FRONT VIEW

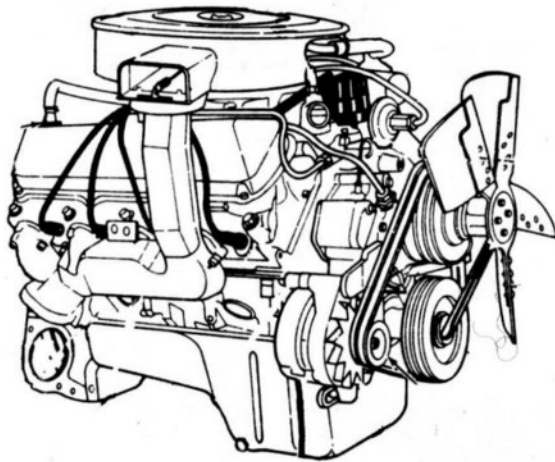
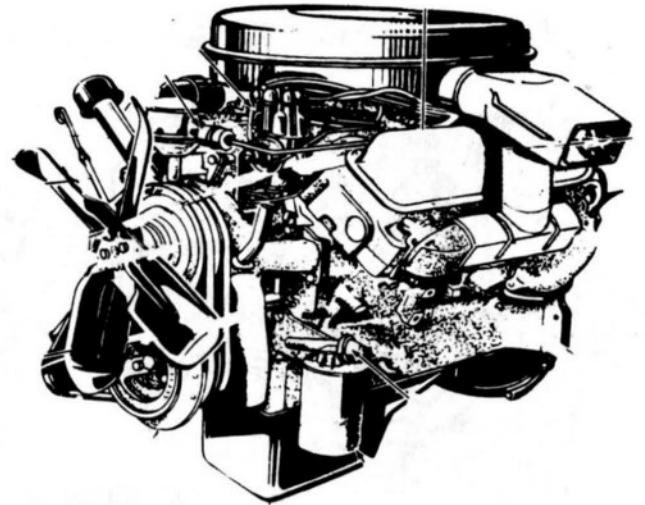
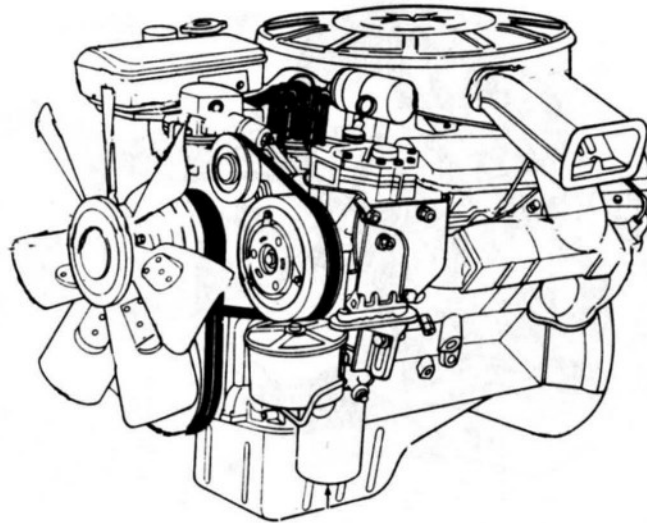

RIGHT-FRONT VIEW

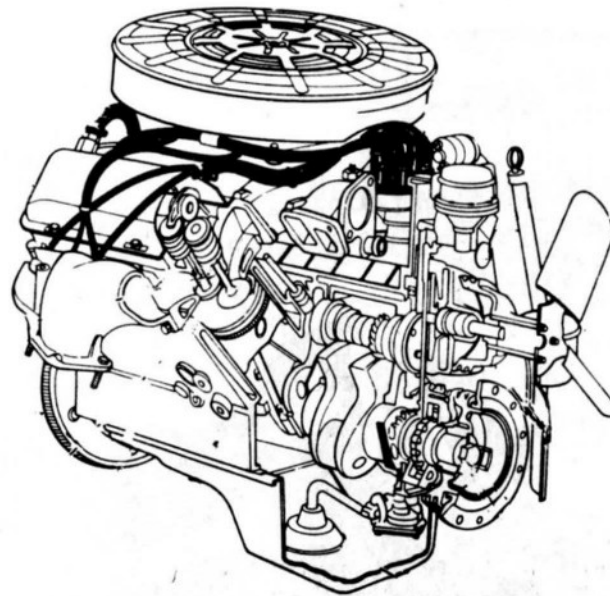

8-462 TYPICAL
Picture 1967-68

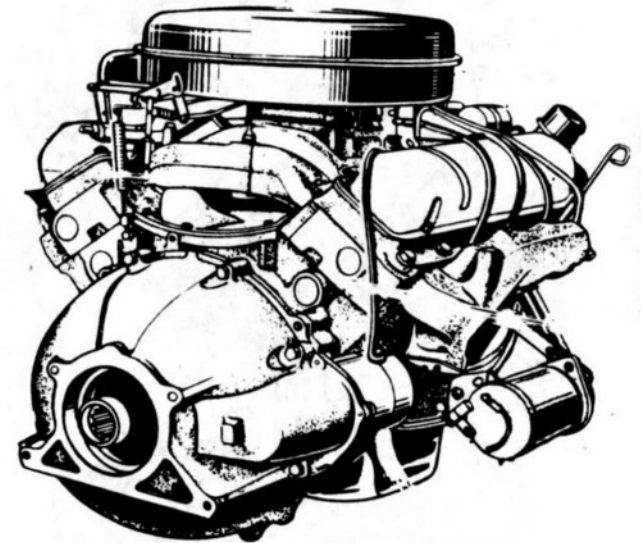

8-430, 462
Picture 1965-66

8-429, 460 TYPICAL
Picture 1968-72